

Battery Saver™ LOW VOLTAGE DISCONNECT

SMART BATTERY PROTECTION

Keep your vehicle's power system running strong with the 4044 Smart Battery Protection Module. Designed for reliability, it automatically disconnects auxiliary power draws when voltage drops too low, preventing dead or deeply discharged batteries. Once the battery recovers, a simple manual reset gets you back on the road—no surprises, no downtime, just smarter power management.



- 11.5v POWER CUT OFF**
Prevents dead batteries
- DIAGNOSTIC LED LIGHT**
Lets you know fault status
- NO SWITCH RESET**
Automatically resume operation
- EASY INSTALLATION**
Reverse battery protection
- MULTIPLE PROTECTIONS**
Low, thermal, overload, ground
- MULTIPLE CONFIGURATION**
Battery OR load separator

Reliable Power Protection & Performance

Ensure your system operates at peak efficiency with our advanced power management board. Designed to handle demanding applications, it supports an input voltage range of +9.5VDC to 18.5VDC, with a typical operating voltage of 13.8VDC. Delivering a continuous 200A to the load and peaking at 250A at 185°F (85°C), this board is built for high-performance reliability.

Intelligent Protection for Unmatched Safety

Equipped with smart fault detection, the system automatically disconnects the load to prevent damage from reverse polarity, current surges, overcurrent, under-voltage, short circuits, and excessive heat. Additionally, when battery voltage drops below 11.5VDC, a 60-second timer ensures a controlled power cutoff, safeguarding your equipment.

Seamless Control & Recovery

A dedicated control input allows for quick fault clearance, ensuring minimal downtime and uninterrupted operation. Experience the next level of power protection with a solution designed for durability, efficiency, and peace of mind.

| SPECS | Part: 4044 |
|--------------------------|---|
| Input Voltage | 12 - 18 volts |
| Low Voltage Trip | 11.5 Volts |
| Nominal Current | 200A (250A surge) |
| Short Circuit Limitation | 350 A |
| Operating Temp Range | -40°F - 185°F |
| Shutoff Delay | 60 seconds |
| Dimensions (L x W x H) | 5.2" x 4.14" x 1.4" 132mm x 105mm x 35mm |

Design it. Source it. Manufacture it. Stock it. Ship it.

PolyElectronics.us



4400 Wyland Dr
Elkhart, IN, 46516
574.522.0246
info@polyelectronics.us
EST 1973

Battery Saver™ LOW VOLTAGE DISCONNECT

TECHNICAL INFORMATION

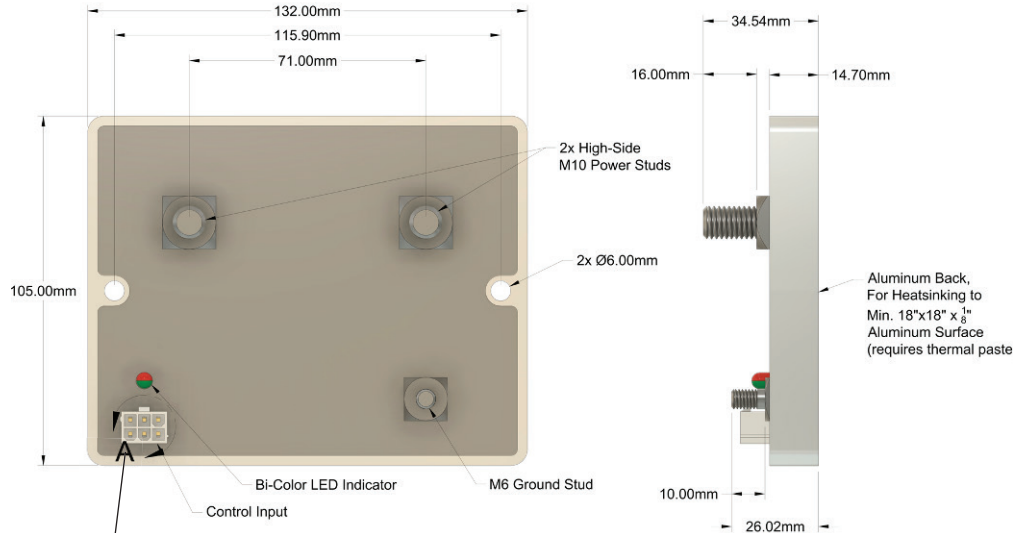

MECHANICAL SPECS

- L x W x H: 5.2" x 4.14" x 1.4"
132mm x 105mm x 35mm
- Power Studs: M10 Thread, with Stainless Steel Nut, No Washer
- Ground and Control: M6 Stud, with Stainless Steel Nut, No Washer
- Molex MiniFit Jr. for Controls and Dashboard Indicator
- Dual Mounting Holes, 0.230" / 6mm Diameter, 4.550" / 116mm Apart
- T6061 Aluminum Back, isolated to 200V, requiring thermal paste or silicone thermal pad for dissipation

RELIABLE & AUTOMATIC MONITORING and DISCONNECT

Built for tough conditions, 4044 handles high-power loads and includes multiple safety features to prevent damage. With a connection to dash-mount indicators and controls, it ensures your equipment stays protected and ready to go.

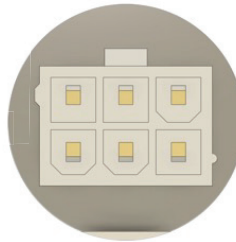

Pinout on Molex Mini-Fit

- 1.) Control Input (Bottom Right)
- 2.) External Red LED (Bottom Middle)
- 3.) NC (Bottom Left)
- 4.) Ground (Top Right)
- 5.) External Green LED (Top Middle)
- 6.) NC (Top Left)

WIRING DIAGRAM

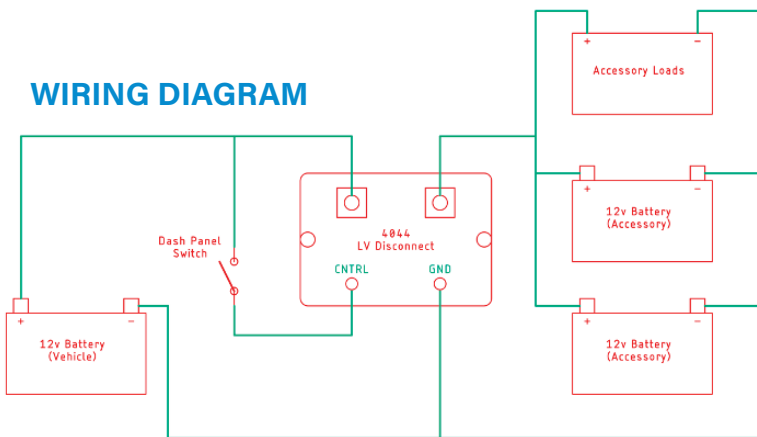

Technical Data

| | |
|--------------------------------|------------------|
| Operating Voltage | 11.6 - 16 volts |
| On Resistance | 450 uΩ +/-100uΩ* |
| Current Limitation | 250 A |
| Voltage Drop @ 200A | 90 mV +/- 5mV* |
| Overtemp Trip | 85 °C |
| Quiescent- Active/Disconnected | 8 mA/4mA |
| Switching Cycles | >100,000 Cycles |
| Reverse Current Protection | Optional |

*Lowest in the industry



PolyElectronics.us

4400 Wyland Dr
Elkhart, IN, 46516
574.522.0246
info@polyelectronics.us
EST 1973



Advanced Electronic Custom Controls Made Easy.

- FAST** - 4 weeks from first contact to product implementation.
RELIABLE - Latest in precision equipment delivers minimal defects.
VALUE - Design and Service at a fraction of the cost.

